

ALKALINE-MANGANESE DIOXIDE BATTERY

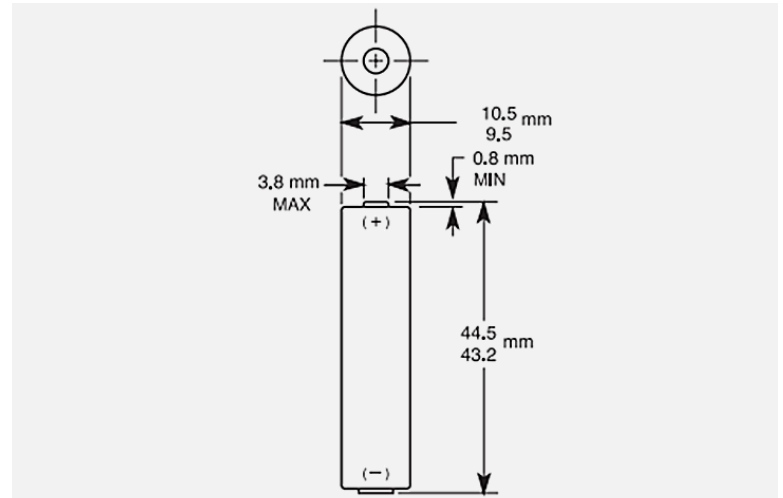

Size: AAA (LR03) PX2400



Dimensions shown are IEC standards

KEY FEATURES

- Reliable Performance
- Excellent resistance to corrosion
- Designed to meet all major quality, safety and environmental standards:
 - Safety: IEC 60086-5
 - ANSI C 18.1M, Part-2
 - EU Battery Directive
 - Quality: ISO 14001 and 9001, Duracell World Class Continuous Improvement Program

TYPICAL APPLICATIONS

- Blood pressure monitors
- Soap dispensers
- Flashlights
- Pulse oximeters

ELECTRICAL CHARACTERISTICS

- Nominal capacity (5 mA Cont., .8V cut-off) 1,461 mAh
- Typical Voltage (at + 20 °C) 1.5 V
- AC Impedance @ 1kHz 129 mΩ

PHYSICAL CHARACTERISTICS

- Typical weight 11.6 g (0.4 oz)
- Typical volume 3.5 cm³ (0.2 in³)
- Terminals Flat

OPERATING & STORAGE CONDITIONS

- Operating temperature range -20°C to 54°C (-4°F to 130°F)
- Recommended Storage (storage area should be clean, cool, dry and ventilated) 5°C to 30°C (41°F to 86°F)

TYPICAL PERFORMANCE

Constant Current

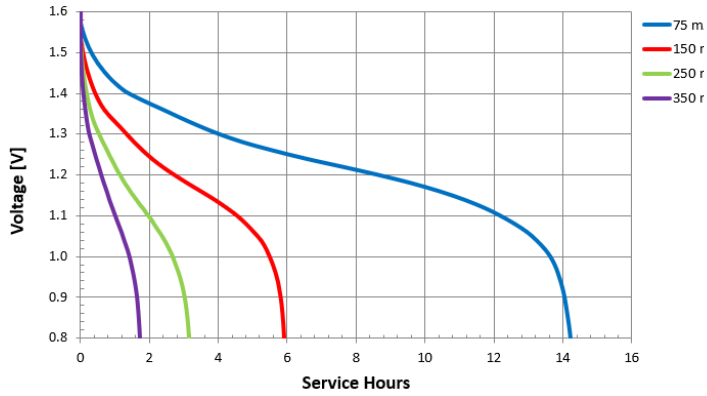

Constant Resistance

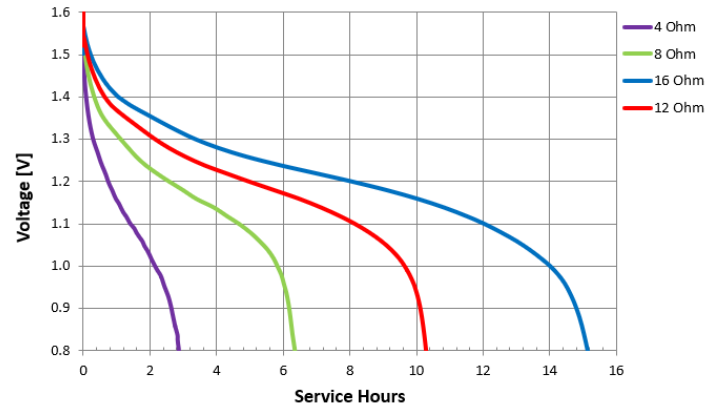

Constant Power

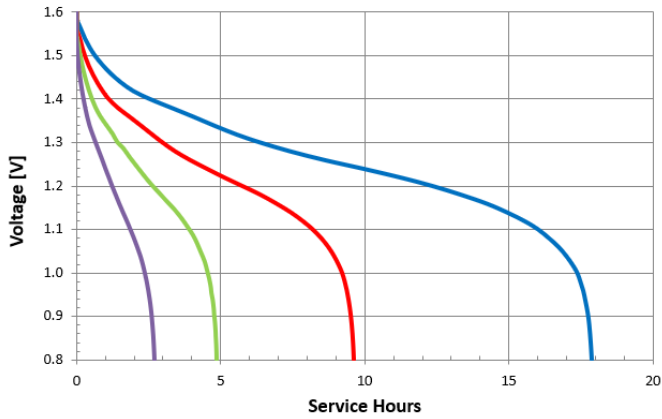

Constant Temperature - 150 mA

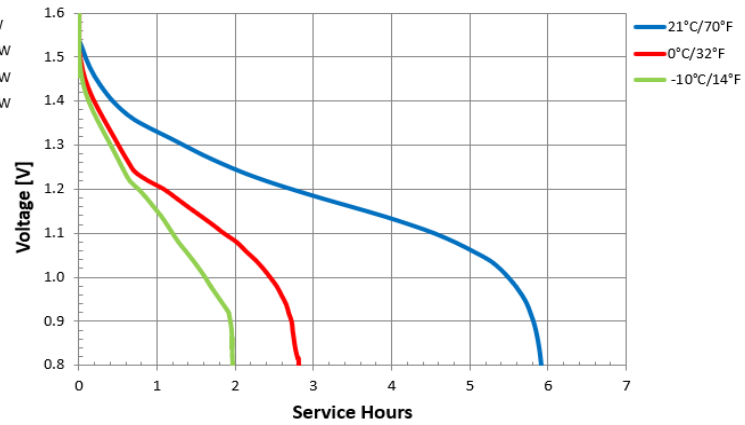

Typical Internal Resistance

High Rate: 0.3A/5 min - 0.6A/1 sec to 0.8V
Low Rate: 0.03A/5 min - 0.15A/1 sec to 0.8V

